

Swing Gate

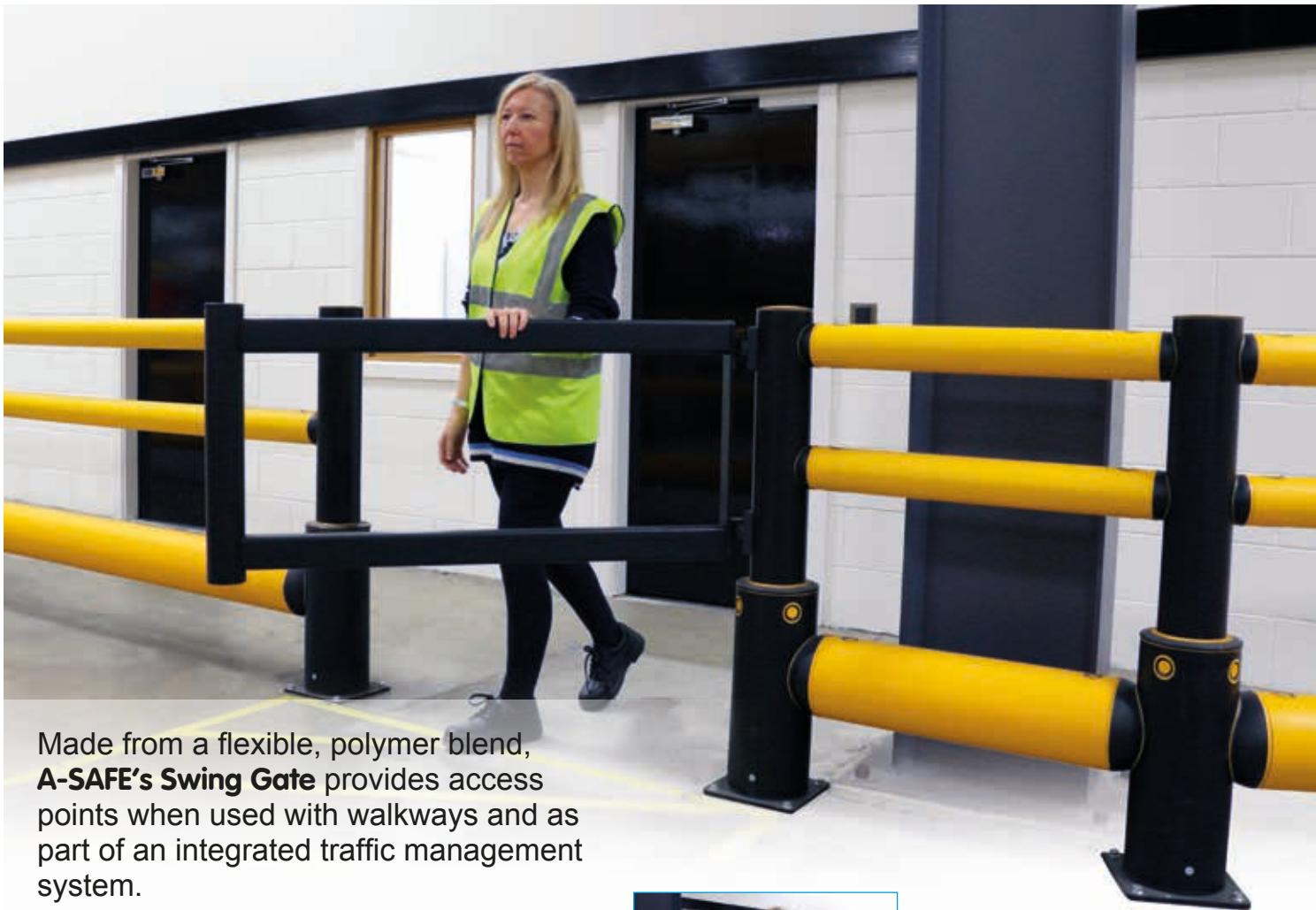

Made from a flexible, polymer blend, **A-SAFE's Swing Gate** provides access points when used with walkways and as part of an integrated traffic management system.

QUALITY & CONFIDENCE

Tested and independently verified by TÜV, all **A-SAFE** barriers come with the reassurance of being the strongest, most innovative products from the global industry leaders.

MODULARITY & VISIBILITY

In-built modularity assists install and repairs and the high-visibility properties make prevention of accidents a priority.

HYGIENIC & ULTRA-LOW MAINTENANCE

Hygiene seals and no ingress points are revolutionary for sensitive environments and the non-scratch, non-corrosive, non-repaint properties of the system create huge savings.

GUIDANCE & PROTECTION

Essential as part of pedestrian walkways, **Swing Gates** will manage access to dangerous vehicle zones and provide clear and durable entry/exit points.



“ We service the power cars, which are the engines of the train, and therefore big units. We need to have access to these but also adequate protection once we are working on them. Therefore, **A-SAFE's** solution of Pedestrian Barriers with Swing Gates is ideal – practical and offering maximum protection.

FIRST GREAT WESTERN
Depot Manager

PROTECTING...

PEOPLE, PROPERTY, PROFITS AND PERFORMANCE



2014

Swing Gate



**GATE POST
PEDESTRIAN HANDRAIL
IFLEX BARRIER**

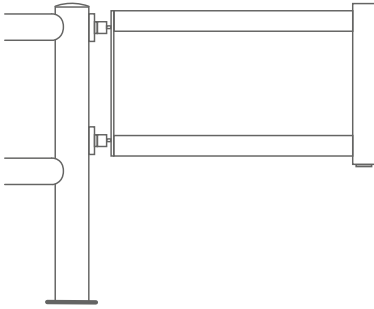

**GATE POST
PEDESTRIAN +3
IFLEX BARRIER**

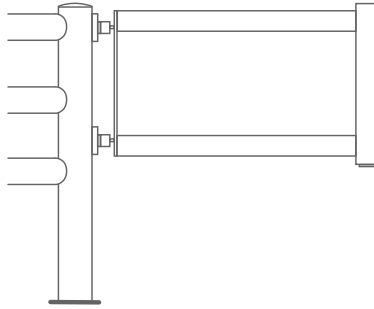

DIMENSIONS

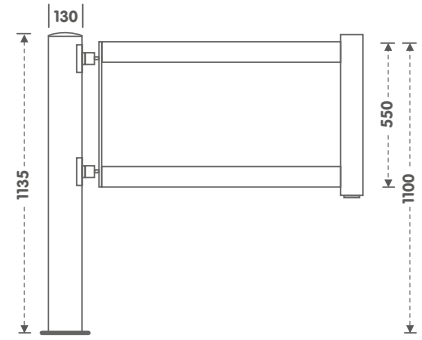

**GATE POST
PEDESTRIAN +4
IFLEX BARRIER**

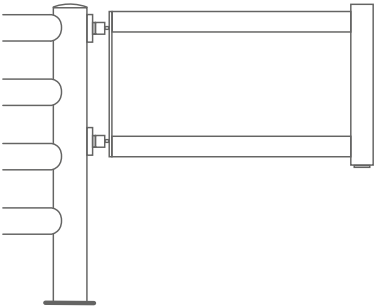

**GATE POST
TRAFFIC PLUS IFLEX BARRIER**

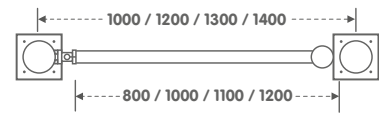
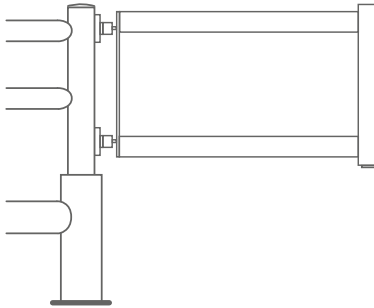

All dimensions in mm

GATE & POST CONFIGURATIONS

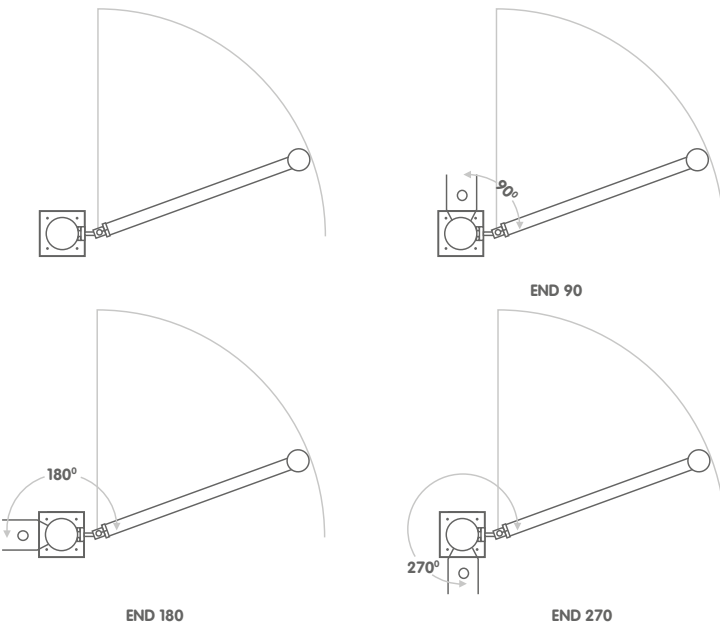

COMPONENTS



Available colours: Yellow, Black and Grey



Find out more, contact sales +44 (0) 1422 331133, email sales@asafe.com or visit www.asafe.com